

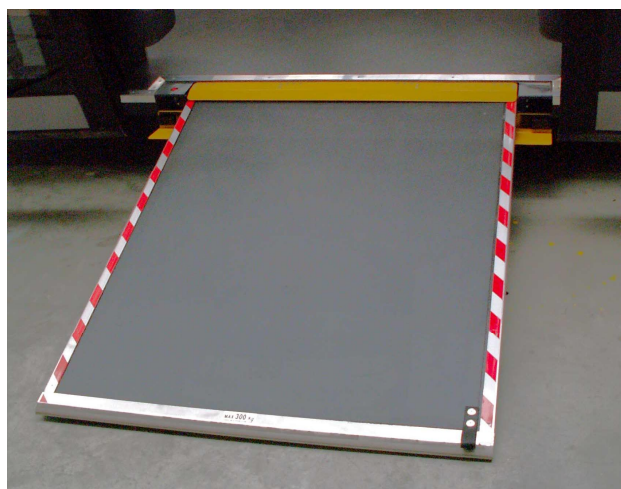

MOCR 1000 Ramp

Manual



ACDEOS BV
Loevestein 17
2352 KN Leiderdorp
Netherlands
WWW.ACDEOS.COM

Date: Mar 2011
Rev. 0

Index

1 Technical specifications2

2 Safety instructions3

3 Constraints3

4 Controls4

 4.1 Ramp Control 4

 4.2 Signals 4

 4.3 Legal requirement according 2001-85 EC:..... 4

 4.4 Electrical Components 4

5 Operation4

 5.1 Deploy Operation procedure..... 4

 5.2 Stow operation procedure 4

6 Mounting / Installation5

7 Repair5

 7.1 Disassembly 5

 7.2 Assembly..... 5

8 Environment5

9 Certification6

10 Spare parts7

11 Appendix 1; Installation drawings:10

1 Technical specifications

Product description	Manual operated ramp for mounting outside under the floor of a vehicle.
Installation	Under the vehicle Floor at the front- middle or rear door
Dimensions	Ramp length 1000 mm - width 880 mm For detailed dimensions please refer to the installation drawings
Weight	total 28 Kg.
Load	Maximum load 300 Kg (3000 N) this is always labeled on the ramp.
Materials	Frame; steel plate work, powder coated. Ramp: Polyester sandwich plate with Stainless steel edges.
Electric signals	following electric signals are available: Ramp closed / stowed.
Legislation	The product fulfils 2001/85 EC Bus directive and 98/37 EC Machine directive.

2 Safety instructions

These Safety instructions should always be with the ramp. The operator must be made aware of these instructions before operating the Ramp. Read these safety instructions carefully and follow them.

The ramp is constructed to be a ramp to enter a low floor vehicle with a wheelchair. It should be used appropriately by passengers as long as they are not heavier as the maximum load, to enter or exit a low floor minibus.

1. **Before you can operate the ramp you have to stop the Vehicle and make sure that the hand or park brake is on.**
2. **Before you operate the ramp, make sure that there is no person or obstacle at or close to the ramp. Look out that there is no person or obstacle outside the vehicle in the motion direction of the ramp.**
3. **It is recommended that the ramp is only operated by the driver or other qualified operators.**
4. **The driver or operator must have a clear view at the ramp when he is operating the ramp.**
5. **It is recommended to stay at the center of the ramp platform.**
6. **NEVER drive away when the RED LED light is still on. The ramp is not properly stowed.**
7. **The ramp platform must be kept clean and free of oil and other slippery materials.**
8. **When you have any doubt about the safety of passenger when using the ramp make sure he is assisted.**
9. **For any questions about the safe operation of the ramp, directly contact the responsible persons.**
10. **Never use the ramp for any other use than here described.**
11. **Never overload the ramp.**
12. **The ramp should always be operated until it is fully in or out.**
13. **Repair and maintenance must be done by qualified and trained staff only.**
14. **Only use original parts if you have to exchange parts from the ramp.**
15. **If the anti slip profile at the ramp becomes slippery because of wear, the ramp platform must be replaced.**
16. **Always use the recommended cleaning materials.**
17. **Report any unsafe condition of the ramp, or during it's operation, to the ramp supplier.**

3 Constraints

The Ramp has been designed to be functional and reliable. The product is made as simple and reliable as possible. It has been taken in consideration that the ramp will be mounted under a vehicle in severe environmental conditions

4 Controls

4.1 Ramp Control

The ramp control is made as easy as possible. The controls comply with European 98/37 EC machine directives. Functions and measurements are compliant with the EU Bus directive 2001/85 EC.

4.2 Signals

The following output signals are available from the ramp:

- Ramp stowed and ramp door closed.
There is an proximity switch located at the door, indicating that the ramp door is closed.

4.3 Legal requirement according 2001-85 EC:

- Driver must have an indication that the ramp is fully stowed.
- Maximum gradient of 12% at floor height of 270 mm at a 150 mm curbstone.
- Rounded edges with minimum radius of 5 mm

The Ramp On fulfils all these requirements.

4.4 Electrical Components

All electrical components directly outside the ramp cassette are water resistant to IP 65.

5 Operation

5.1 Deploy Operation procedure

The vehicle must have the parking brake on, and then the ramp can be safely operated.

Unlock the two door locks. There are two versions of door locks:

1. **Sliding**

Slide those to the center of the door and than open the door.

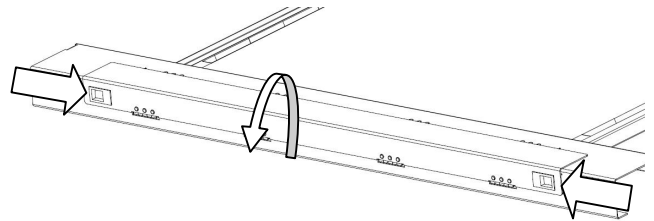

2. **Turning**

Unfold the turning arm of the lock and turn it a ¼ turn clockwise at the right lock and anti clockwise at the left lock.

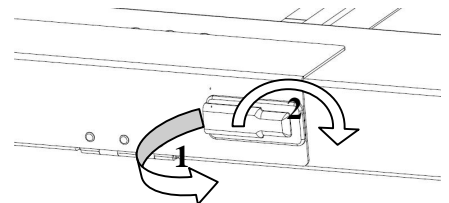

Open the door, lift the yellow flap under the door, put a finger in the nylon strap and pull out the ramp about 30 cm. Than take it with both hands on both sides and pull out the ramp completely until it can not slide any further, and than gently lower it to the ground

5.2 Stow operation procedure

Lift the ramp from the ground until the end is a little higher as the bus floor. Slide the ramp in under the bus floor lowering the end to come Horizontal when you slide ramp in the cassette. Push it until the front edge has past the ramp door and the door can be closed.

Close the ramp door.

Sliding door locks:

Push the door firmly on both sides and the locks will lock automatically

Turning locks

Close the door and push it firmly. Turn the lock to close and place the turning link back in closed position.

6 Mounting / Installation

The installation must only be done by a company that is well known with bodybuilding or modifying vehicles, which has the trained technical staff to do this job.

For installation details; contact the supplier of the ramp.

7 Repair

The repair of the ramp is simple and can be done with the normal available workshop equipment.

7.1 Disassembly

The ramp can be removed from the cassette by removing the buffer block at the side of the ramp. Once they are removed the ramp platform can be removed from the cassette.

Than small parts can be replaced.

7.2 Assembly

Slide the platform in the cassette and place the buffer blocks back in place.

8 Environment

The AXS - Ramp is made of durable materials which all can be recycled. All different materials can easily be separated from each other for separate recycling.

9 Certification

Certification

Product	Product description AXS RAMP
Type	Manual operated Sliding ramp MOCR 1000 A

Company	Production under responsibility of Acdeos BV
Address	Loevestein 17
City	2352 KN Leiderdorp
Country	Netherlands
Website	WWW.ACDEOS.COM
Legal represented by	Mr. A de Moes

Conformity
Product is designed, tested and produced conform:
The loading recommendations in the Machine directive 98/37/EG
Ramp is tested for a maximum weight of 300 Kg

On behalf of producer:
Name / Function
A de Moes / Engineering
Date
15 September 2009
Place
Leiderdorp, Netherlands



10 Spare parts

Chassis

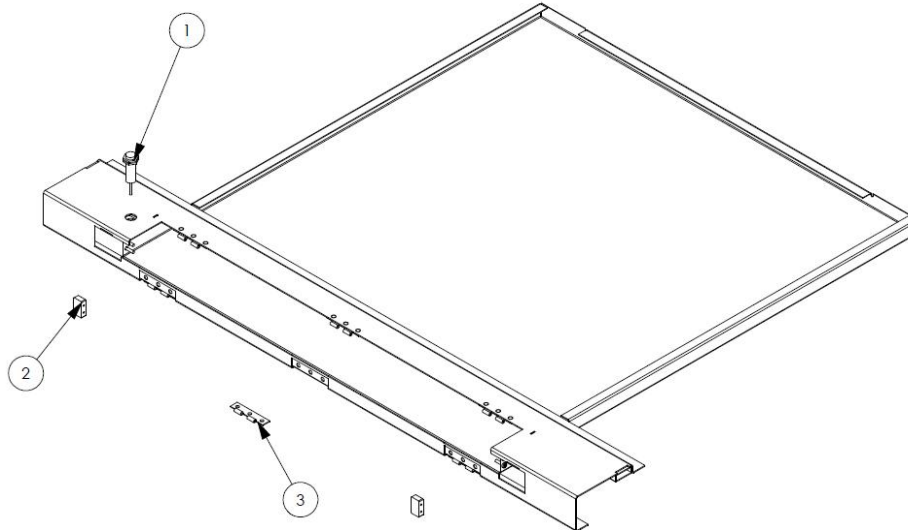

item	Part	Part number
1	Proximity switch	C148 001
2	Buffer block	C134 04 03
3	Hinges (3 / door)	C134 03 09
1	Hinges (4 / door)	C134 03 08

Ramp assembly

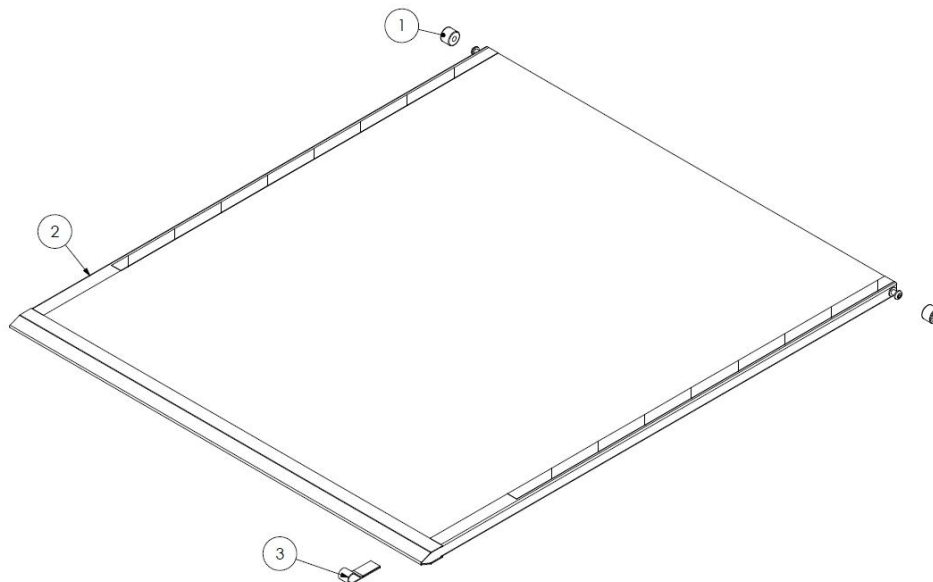

item	Part	Part number
1	Wheel	C134 02 07
2	Platform complete	C148 02 01
3	Pull strap	C148 02 12

Door assembly sliding locks

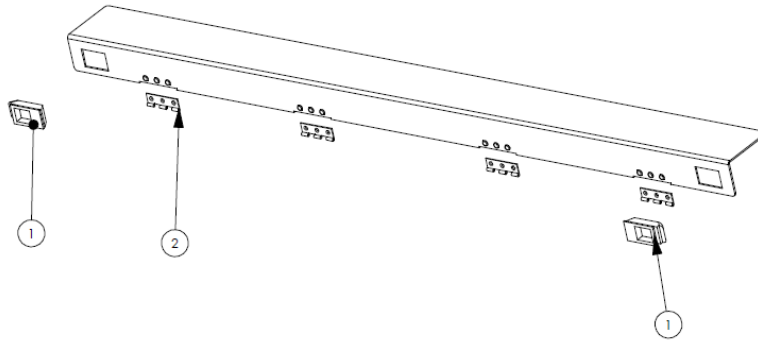

item	Part	Part number
1	Sliding lock	C148 04 03
2	Hinge (at 4 hinges / door)	C134 03 08

Door assembly turning locks

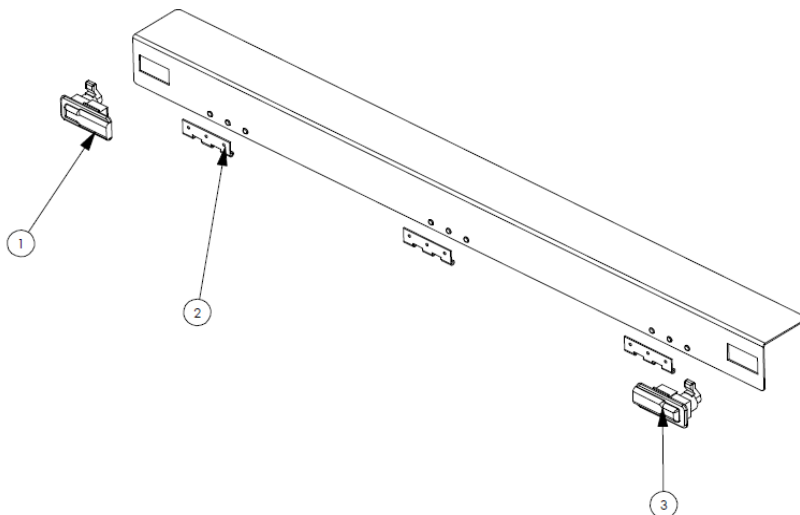

item	Part	Part number
1	Turning lock left	C148 04 05
2	Hinge (3 / door)	C134 03 09
3	Turning lock Right	C148 04 04

Flap assembly

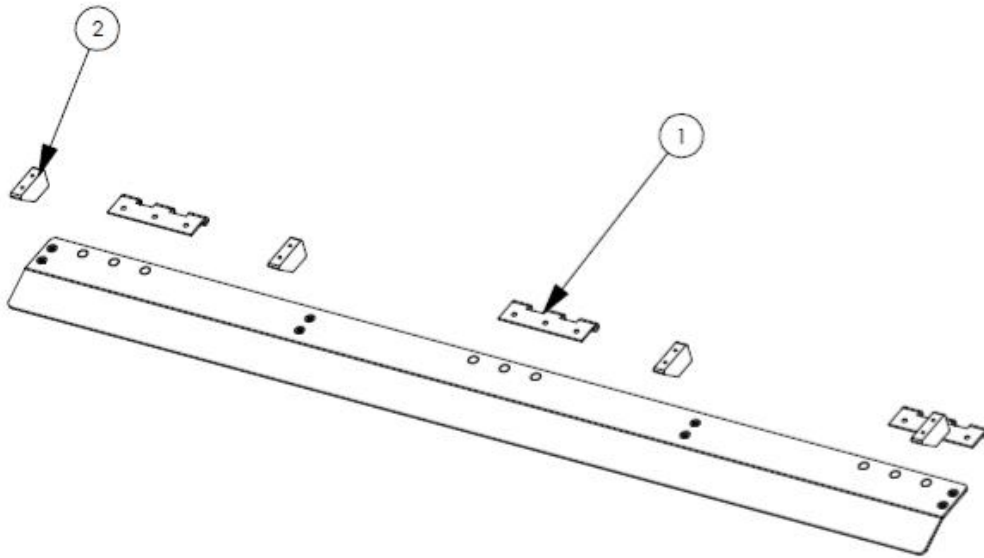

item	Part	Part number
1	Hinge (3 / flap)	C134 03 09
1	Hinge (4 / flap)	C134 03 08
2	Sliding block	C148 05 03

11 Appendix 1; Installation drawings:

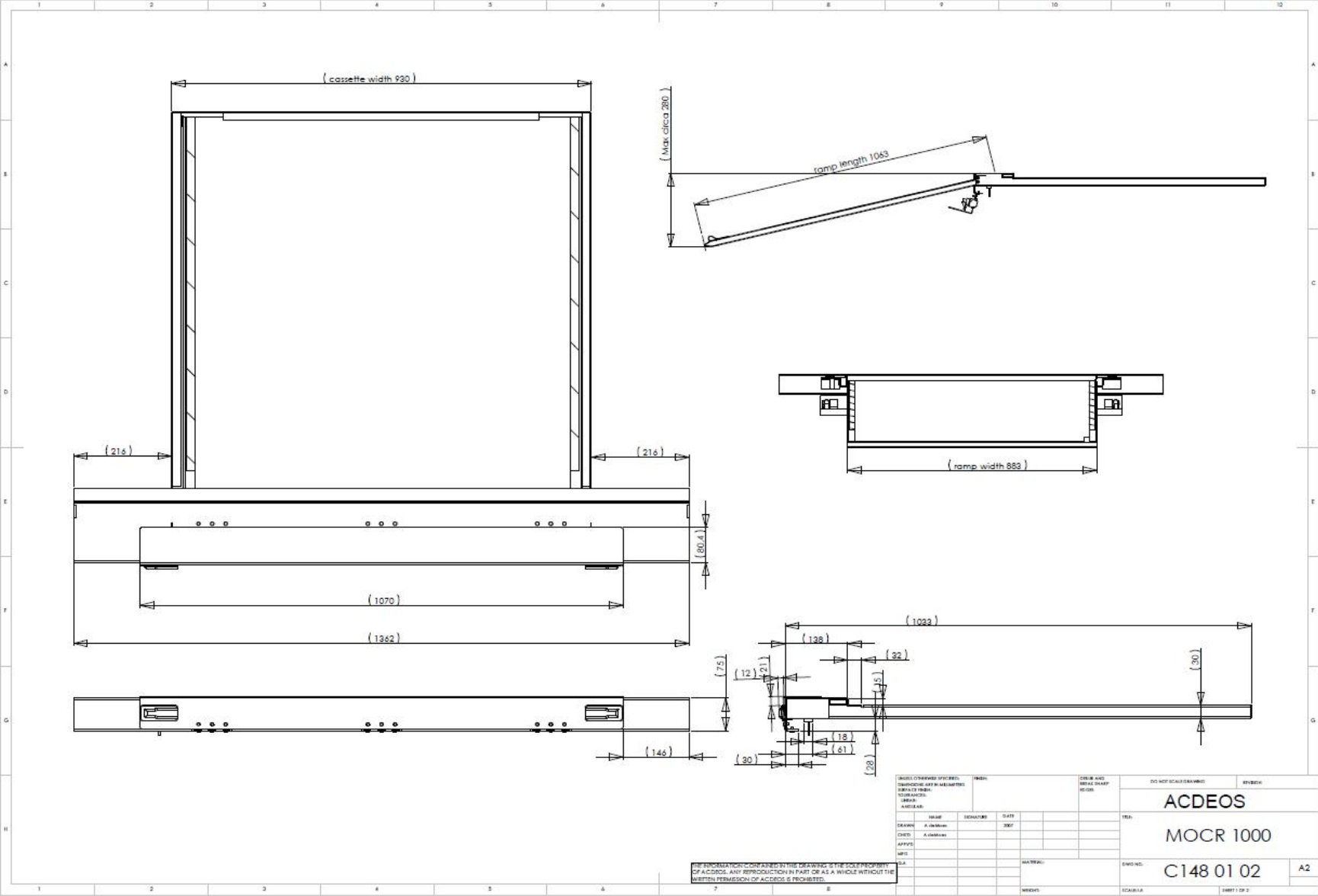

THE INFORMATION CONTAINED IN THIS DRAWING IS THE SOLE PROPERTY OF ACDEOS. ANY REPRODUCTION IN PART OR AS A WHOLE WITHOUT THE WRITTEN PERMISSION OF ACDEOS IS PROHIBITED.

<small>UNLESS OTHERWISE SPECIFIED: DIMENSIONS ARE IN MILLIMETRES UNLESS OTHERWISE SPECIFIED</small>				<small>DATE AND RELEASED DATE</small>		<small>REVISED</small>	
<small>ACDEOS</small>				<small>YES</small>		ACDEOS	
<small>DESIGN: A. de Mores</small>				<small>DATE: 2007</small>		<small>YES</small>	
<small>CHECK: A. de Mores</small>						MOCR 1000	
<small>APPROVE:</small>						<small>ENGINEER:</small>	
<small>DATE:</small>				<small>SCALE:</small>		C148 01 02	
<small>NO.:</small>				<small>REVISIONS:</small>		A2	
						<small>SCALE: 1:1</small>	
						<small>SHEET 1 OF 2</small>	